



WE RAISE THE BAR. WE SET THE STANDARD.

Project \_\_\_\_\_

Item Number \_\_\_\_\_

Quantity \_\_\_\_\_

SRM80+ Mixer



## 80 Quart (qt.) Floor Model Mixer MADE IN THE USA

### Model:

➤ SRM80+: 80 QT. FLOOR MODEL MIXER



Floor Model Mixer

### Features:

- 3 hp capacitor start motor
- Variable Speed Drive: 4 fixed speeds or any speed in-between
- Change speeds without having to stop the mixer
- Two-piece, stainless steel, dishwasher safe safety guard
- Heavy-duty stainless steel bowl
- #12 Power Take-Off (PTO) hub
- Interlock switches protect operator from injury if safety guard is open or bowl is lowered
- Hardened alloy gears in transmission
- Low voltage protection prevents accidental start up after power failure
- Durable NSF approved hybrid epoxy/polyester powder coat finish

### Standard Accessories:

- 15 minute timer
- 80 qt. stainless steel bowl
- Dough hook
- Batter beater
- Wire whip
- Ingredient chute
- Bowl scraper
- Power bowl lift

### Optional Accessories:

- Splash ring
- Cover
- Sweet dough beater
- 80 qt. pastry knife
- Four wing beater
- Bowl truck

### Optional Attachments:

- VS9 vegetable slicer with adjustable knife
- VS9H vegetable shredder with plate holder and 3/16" plate (additional plate size variations, grater plates, and julienne plate available)
- ALMFC12 meat and food grinder

### Warranty:

- Two year, on-site parts and labor

Univex Corporation



Univex Corporation  
www.Univexcorp.com

3 Old Rockingham Rd  
Salem, NH 03079  
United States of America

TEL: (800)258-6358  
INTL TEL: (603)893-6191  
FAX: (800)356-5614  
INTL FAX: (603)893-1249



WE RAISE THE BAR. WE SET THE STANDARD.

# 80 Quart Floor Model Mixer

**SRM80+**

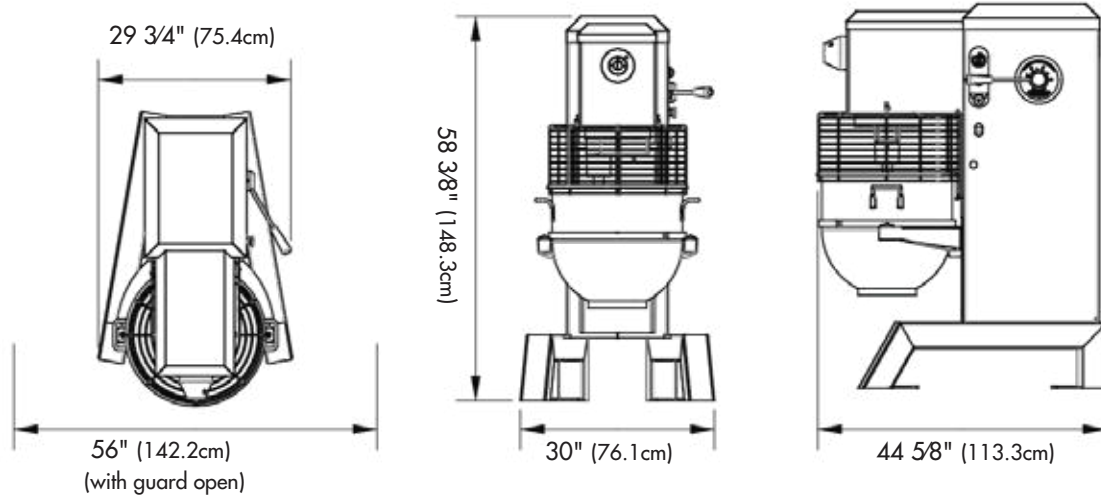

Shipping Information		
Net Weight	Shipping Weight	Overall Dimensions
835 lbs. (378.7Kg)	1000 lbs (453.6Kg)	66" (167.6cm) H x 41" (104.1 cm) W x 51" (129.5cm) D
The weight and dimensions of the pallet are included in the weight and dimensions above.		

Electrical Information (60Hz)				
Attached 6 foot cord				
	Voltage	Phase	AMPS	NEMA
Standard	208-240	1	16.0-16.8	6-20-P
Optional	208-240	3	8.0-8.5	L15-20
	460	3	4.0	L16-20

Mixer Speeds				
Speed	1	2	3	4
Beater Shaft (RPM)	90	166	263	395
PTO (RPM)	90	163	255	387

Bowl Capacity: 80 qts. (75.7 liters)

Motor: 3 hp capacitor start

Controls: Momentary contact stop & start buttons and contactor

Bowl Lift: Ergonomic hand operated crank, self locking in top and bottom position

Lubrication: Oil bath

Transmission: Featuring hardened alloy gearing and torque sensing variable speed pulleys



**Univex Corporation**  
www.Univexcorp.com

3 Old Rockingham Rd  
Salem, NH 03079  
United States of America

TEL: (800)258-6358  
INTL TEL: (603)893-6191  
FAX: (800)356-5614  
INTL FAX: (603)893-1249